

EN

*Ortlinghaus*

**METAL**

forming technology

Engineered for  
your success

# Content



<b>01</b>	Ortlinghaus in metal forming technology.....	4
<b>02</b>	Presses.....	6
02.1	Large H-frame presses.....	6
02.2	Servo presses.....	8
02.3	Forging presses.....	9
02.4	C-frame presses.....	10
<b>03</b>	Clutch-brake units.....	12
03.1	Clutch-brake unit series 123.....	12
03.2	Cee.go series 480.....	14
03.3	Clutch-brake unit series 420.....	16
03.4	Clutch-brake unit series 106.....	18
<b>04</b>	Linear Motion Lock series 055.....	20
<b>05</b>	Clutch series 127 and brake series 128.....	21
<b>06</b>	Prot.act.....	23
06.1	Prot.act series 172.....	23
06.2	Prot.act series 472.....	28
<b>07</b>	Oil inlet.....	30
<b>08</b>	Control unit series 086.....	31
<b>09</b>	DC650.....	32
09.1	Digital protection for your forming machines.....	32
09.2	Hardware and software.....	34
09.3	Benefits.....	36
09.4	Technical data.....	37
<b>10</b>	In good hands from the beginning.....	38
<b>11</b>	Ortlinghaus worldwide.....	39

# Ortlinghaus in metal forming technology

**We have been active in the field of metal forming technology for more than 75 years.** Today, we offer products across the entire spectrum of mechanical presses and servo presses, from clutch-brake units, slide locking devices, brakes to mechatronic control systems. We are the only manufacturer of clutches and brakes successfully developing and producing the friction systems in-house for each and every clutch and brake we deliver to the market. Our mechatronic systems are engineered to address the specific needs of each individual applications.

Ortlinghaus has developed a reputation for quality throughout the world – and we are highly motivated to meet and exceed our previous standards. We work with our customers to create custom solutions and values that are characterized by innovation and superior engineering.

H-frame presses

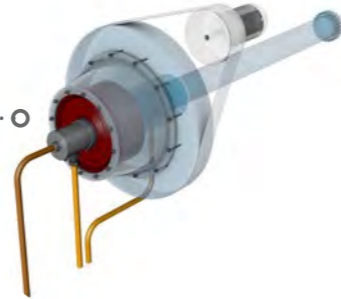

Forging presses

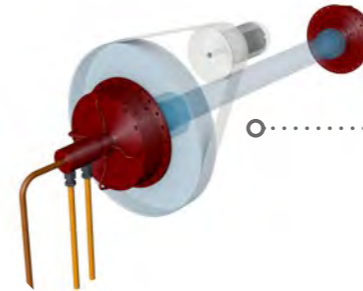

Servo presses



C-frame presses

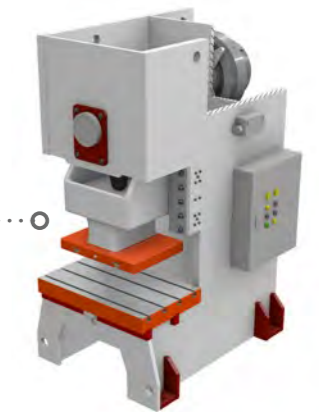

# Presses: Large H-frame presses

**Engineered for higher performance.** These large flywheel presses are mainly used for the production of large and complex formed parts for the automotive industry. The drive system of these presses typically consists of hydraulically actuated, wet-running, multi-plate clutch-brake units. Quite often they include slide locking devices to secure the ram in any position. Ortlinghaus is the preferred supplier to most of the worldwide press manufacturers and recognized in the automotive industry for their outstanding performance, quality, long-life and worldwide after-sales-service.

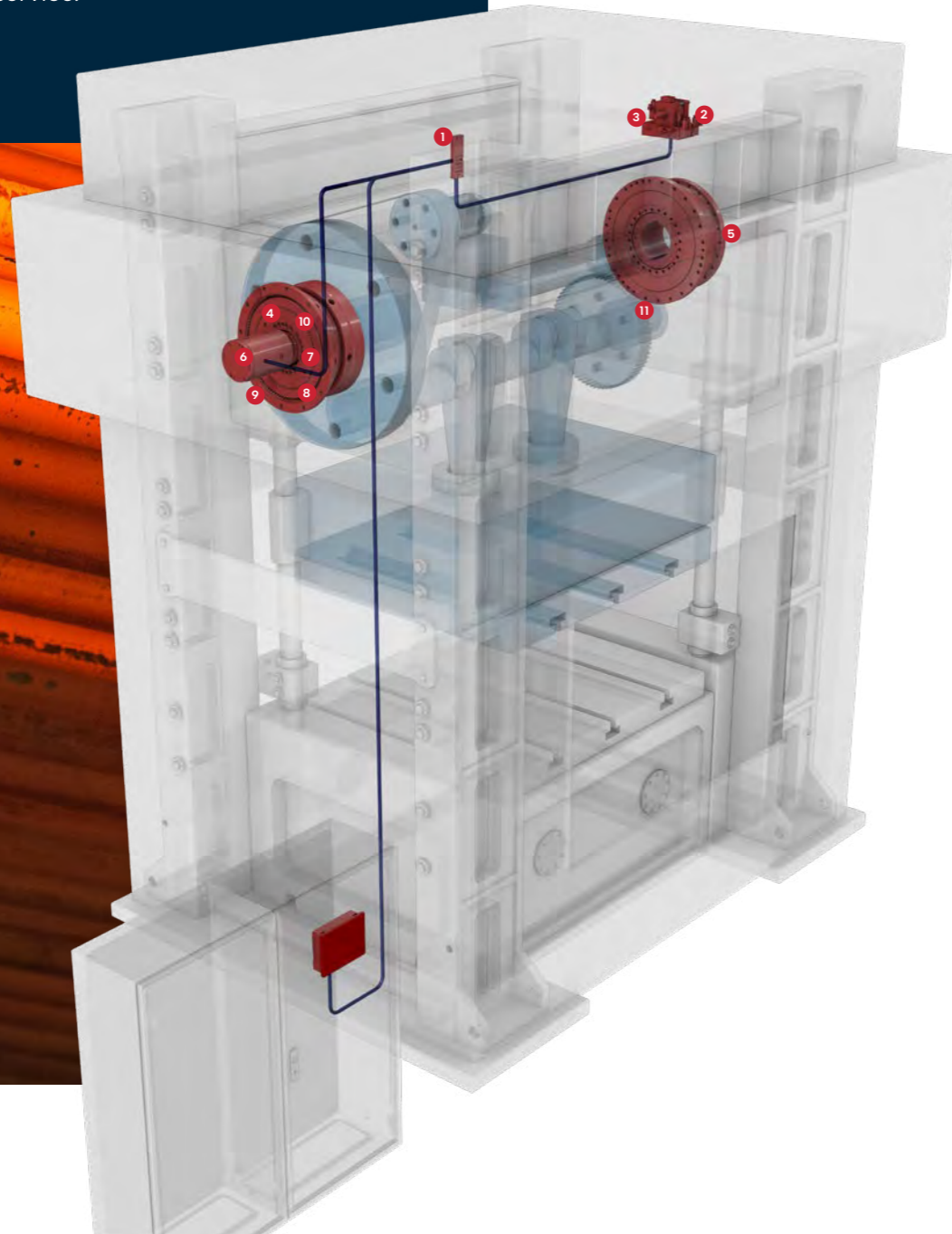

**1 DC650**  
Diagnosis and control platform



**2 Series 086**  
Press safety valve



**3 Series 086**  
Progressive control



**4 Series 127**  
Hydraulic clutch



**5 Series 128**  
Hydraulic brake



**6 Series 088**  
Oil Inlet



**7 Series 123**  
Hydraulic wet-running clutch-brake unit



**8 Series 480**  
Cee.go - pneumatic wet-running clutch-brake unit



**9 Series 106**  
Hydraulic dry-running clutch-brake unit



**10 Series 420**  
Pneumatic dry-running clutch-brake unit



**11 Series 055**  
Linear Motion Lock

## Servo presses

**Protect your press.** Servo presses are characterized by large electrical torque motors, which generates the needed forming energy directly on the shaft. In this application the safety requirements are high and serve to protect the press drive and transfer system as well as to prevent accidents. For these safety reasons, it is necessary to implement a reliable safety brake, which in some cases should be combined with additional slide locking devices. Ortlinghaus is the leading manufacturer for this type of safety brake. With our Prot.act series we brought a unique and innovative design onto the market, it has been specifically designed and created for servo press applications.



**Series 472**  
Pneumatic dry-running  
brake for servo presses



**Series 172**  
Prot.act



**Series 055**  
Linear Motion Lock



**Series 123**  
Hydraulic wet-running  
clutch-brake unit



**Series 127**  
Hydraulic clutch



**Series 128**  
Hydraulic brake

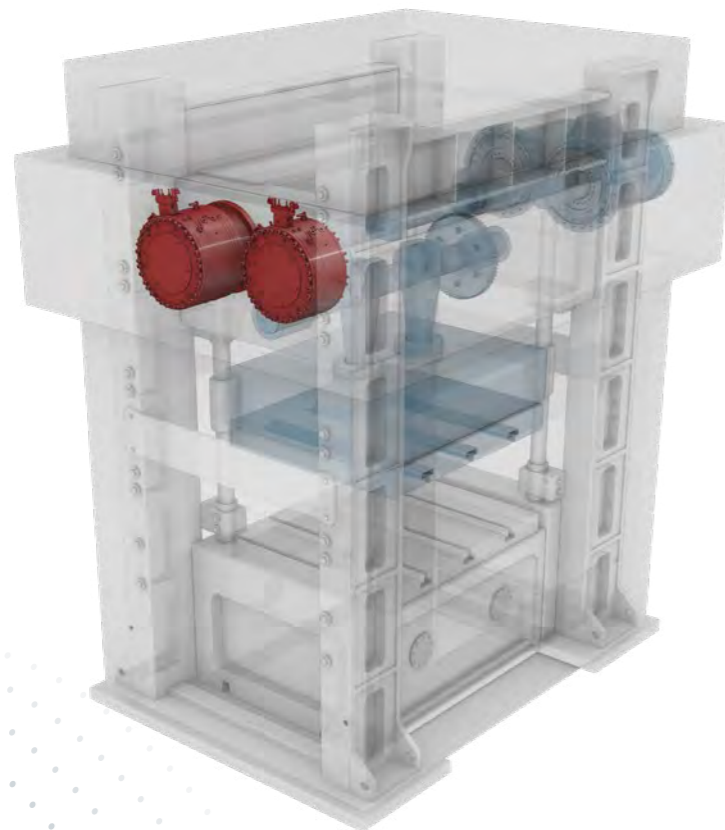

## Forging presses

**Achieve highest level of reliability.** Mechanical forging presses with flywheel drives are suitable for the mass production of forged parts. Ortlinghaus provides a wide range of solutions for mechanical forging presses, such as separate clutches and brakes as well as clutch-brake units. All utilize Ortlinghaus proprietary wet-running friction systems for high output and a very long durability. Ortlinghaus as the sole manufacturer of plates with such large dimensions, can offer frictions systems with transmission torques of up to 1.55 million Nm.

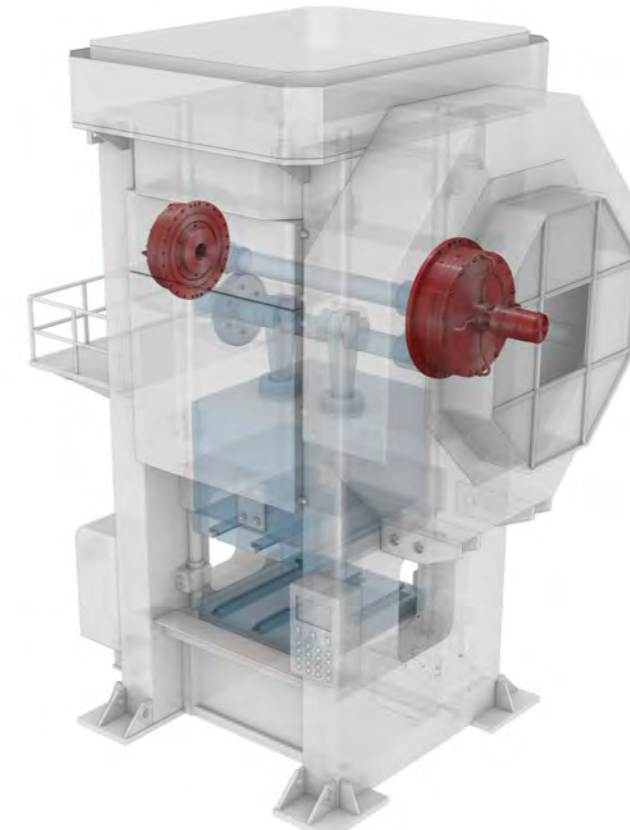

# C-frame presses

Perform better with Cee.go. C-frame presses typically provide capacities from 40 to 250 tons. Most of the machines are equipped with flywheel drives. The presses can be operated manually or automatically. In recent years, Ortlinghaus has supplied many dry-running and wet-running clutch-brake units into this business. Ortlinghaus has newly developed the Cee.go system, providing higher output performance, extended lifetime of the friction system combined in a complete system solution.

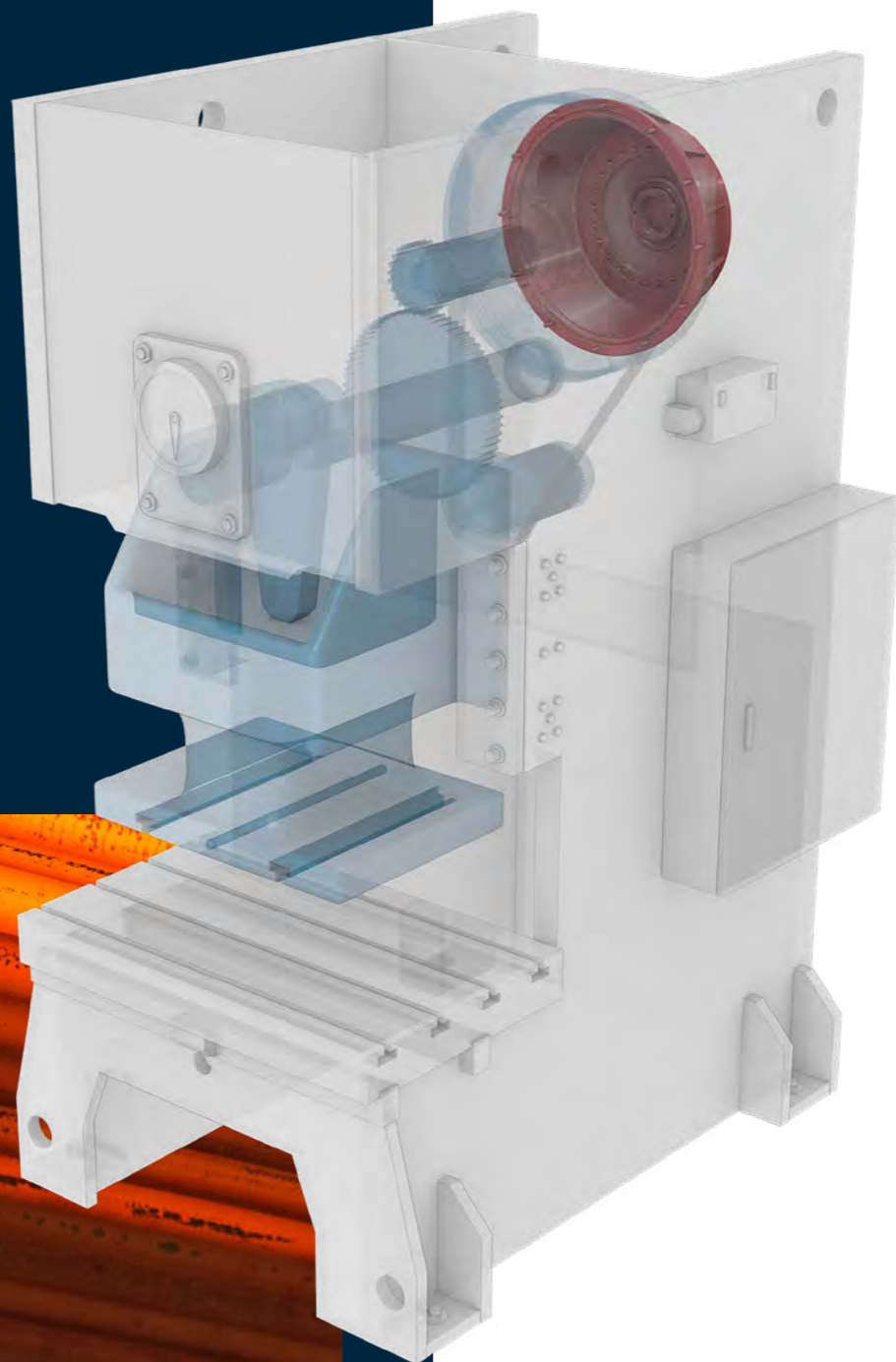

**Series 123**  
Hydraulic wet-running  
clutch-brake unit



**Series 480**  
Cee.go - pneumatic wet-running  
clutch-brake unit



**Series 106**  
Hydraulic dry-running  
clutch-brake unit



**Series 420**  
Pneumatic dry-running  
clutch-brake unit



# Clutch-brake units: Clutch-brake unit series 123

The hydraulic clutch-brake units from the series 123 work exclusively with Ortlinghaus proprietary wet-running, oil-cooled plates with friction pairing steel/sinter. This multi-plate design and the oil cooled friction pairing of steel and sinter offer a compact design and a high operating efficiency with high torque, low moment of inertia, high engagement frequencies and a minimal need of maintenance. The model series 123 operates in sealed housings which prevent leakage, air pollution and reduce engagement noise to a minimum.

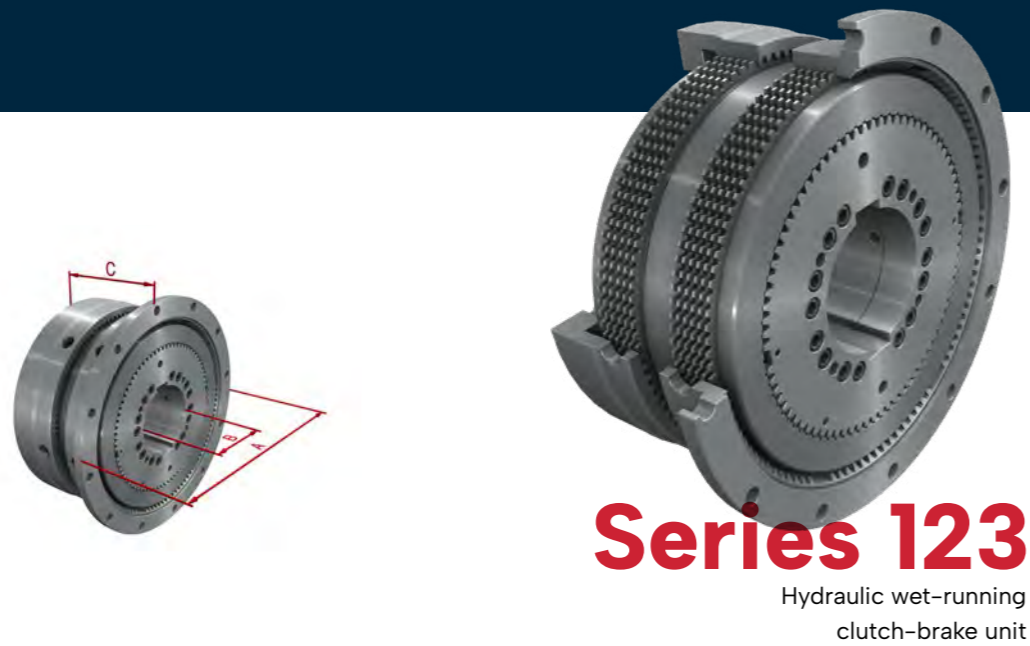

	Feature	Size 75	Size 80	Size 86	Size 90	Size 94	Size 96	Size 98
Min. clutch torque	$T_{stat.}$	4.300 Nm	8.400 Nm	17.300 Nm	34.100 Nm	68.700 Nm	138.600 Nm	277.900 Nm
Max. clutch torque	$T_{stat.}$	12.000 Nm	23.300 Nm	56.800 Nm	115.700 Nm	261.400 Nm	513.200 Nm	967.600 Nm
Min. brake torque	$T_{dyn.}$	1.600 Nm	3.300 Nm	6.600 Nm	15.000 Nm	47.000 Nm	87.700 Nm	147.600 Nm
Max. brake torque	$T_{dyn.}$	3.300 Nm	6.700 Nm	15.900 Nm	35.900 Nm	112.700 Nm	210.500 Nm	354.100 Nm
Operating pressure	$p_B$	63 bar	63 bar	63 bar	63 bar	87 bar	86 bar	84 bar
Speed	$n$	1.300 min <sup>-1</sup>	1.000 min <sup>-1</sup>	850 min <sup>-1</sup>	700 min <sup>-1</sup>	500 min <sup>-1</sup>	415 min <sup>-1</sup>	350 min <sup>-1</sup>
Outer diameter	A	290 mm	380 mm	440 mm	560 mm	710 mm	870 mm	1.180 mm
Max. bore diameter	B	95 mm	130 mm	160 mm	200 mm	250 mm	310 mm	375 mm
Length	C	177 mm	222 mm	325 mm	365 mm	508 mm	602 mm	725 mm



### High torque density

The multi-plate design with oil cooled friction pairing of steel and high-performance sinter ensures high and consistent torque availability.



### Optimal maintenance conditions

Long maintenance intervals and a high durability lead to less service expenses.



### Easy integration

Due the compact design and the customizable interfaces with keyway connection or clamping devices, for the connection to the shaft, the 123 series clutch-brake unit can be easily integrated in different press designs.



### High press availability

An optional housing cover, including Buna or Viton seal, can be supplied with the clutch-brake unit to seal the hydraulic system. This saves customers the time and effort of manufacturing their own cover.



### System supplier

The clutch-brake unit can be supplied with an oil inlet, press safety valve or control unit and electronic slipping control (ESC). The ESC continuously monitors important aspects of the engagement sequence to prevent the clutch from thermal overload.



### High engagement frequency

The multi-plate design and the low moment of inertia of the series 123 combined with the Ortlinghaus progressive control guarantees shortest response times and high engagement frequencies, which leads to higher output rates.



### Modular design

The multi-plate design makes it possible to achieve a wide range of torques with each given size of this series, and the different housing options allow flexible integration into various press designs.

# Cee.go series 480

The Cee.go is an innovative wet-running and pneumatically actuated clutch-brake unit for C-frame presses. Engineered as a complete system consisting of a clutch-brake unit, cover and rotary union, it is provided to our customers as a ready-to-install-package which is easy to adopt to the press and ready for use in a short time. With a wet-running friction system, higher engagement frequencies per minute and a higher output performance of parts per minute can be achieved. With almost no wear on the friction system press downtime is reduced to a minimum and the maintenance costs are significantly lower.

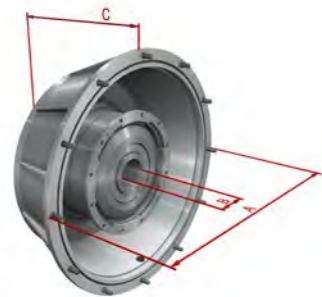

## Series 480

Cee.go – pneumatic wet-running clutch-brake unit

	Feature	Size 75	Size 80	Size 86
Min. clutch torque	$T_{stat}$	4.320 Nm	9.470 Nm	11.480 Nm
Max. clutch torque	$T_{stat}$	7.870 Nm	16.300 Nm	19.400 Nm
Min. brake torque	$T_{dyn}$	1.000 Nm	1.930 Nm	2.230 Nm
Max. brake torque	$T_{dyn}$	2.000 Nm	3.850 Nm	4.460 Nm
Operating pressure	$p_B$	5–6 bar	5–6 bar	5–6 bar
Speed	$n$	450 min <sup>-1</sup>	450 min <sup>-1</sup>	450 min <sup>-1</sup>
Outer diameter	A	640 mm	710 mm	800 mm
Max. bore diameter	B	80 mm	100 mm	120 mm
Length	C	375 mm	390 mm	385 mm



### Design-to-cost

The design-to-cost approach enables us to offer a product with a much higher price performance compared to conventional clutch and brake systems. This aspect covers the entire process from the assembly to the operation of the product for years.



### Wet-running

The Cee.go is a wet-running clutch-brake unit with a high thermal load capability and therefore has a higher performance level in respect of clutch engagements per minute and much less wear compared to dry-running systems.



### Easy integration

The Cee.go can easily be mounted on the press, the total assembly time of the press drive can be reduced significantly.



### System solution

The Cee.go is a 3-in-1 system solution that consists of a clutch-brake unit, an air inlet and a cover.



### No external hydraulics

Since no external hydraulic system is needed, cost of installation and operation is kept low.



### Ortlinghaus quality

The Ortlinghaus quality is evident. For many decades we have been supplying solutions that increase the overall productivity of presses, improve performance and enable our customers to manufacture outstanding machines for the world market.

# Clutch-brake unit series 420

The pneumatically actuated clutch-brake unit series 420 is the most traditional drive concept in the stamping industry over the years. With different types of suspension and a high flexibility in the connection between hub and the shaft of the customer, we typically work with keyways or clamping devices. Installations therefore are most reliable and easy to carry out. Different types of friction elements are available in order to achieve the most effective operating life time and with quiet engagement processes under all operating conditions.



## Series 420

Pneumatic dry-running clutch-brake unit

	Feature	Size 23	Size 29	Size 40	Size 50	Size 61	Size 62	Size 67	Size 72
Max. clutch torque at 5.5 bar	T <sub>stat.</sub>	260 Nm	410 Nm	840 Nm	1.580 Nm	3.450 Nm	3.500 Nm	4.700 Nm	6.600 Nm
Max. clutch torque at 6.0 bar	T <sub>stat.</sub>	280 Nm	450 Nm	920 Nm	1.780 Nm	3.800 Nm	4.000 Nm	5.300 Nm	7.400 Nm
Max. brake torque	T <sub>dyn.</sub>	140 Nm	220 Nm	480 Nm	850 Nm	1.850 Nm	2.500 Nm	3.350 Nm	4.700 Nm
Speed	n	3.200 min <sup>-1</sup>	2.750 min <sup>-1</sup>	2.250 min <sup>-1</sup>	1.750 min <sup>-1</sup>	1.400 min <sup>-1</sup>	1.500 min <sup>-1</sup>	1.400 min <sup>-1</sup>	1.250 min <sup>-1</sup>
12 pt. suspension	A1	182 mm	205 mm	255 mm	325 mm	408 mm	408 mm	450 mm	500 mm
2 pt. suspension short	A2	230 mm	250 mm	315 mm	390 mm	495 mm	495 mm	550 mm	610 mm
2 pt. suspension long	A3	305 mm	325 mm	410 mm	490 mm	635 mm	635 mm	710 mm	790 mm
Max. bore diameter	B	35 mm	35 mm	45 mm	65 mm	80 mm	90 mm	95 mm	105 mm
Length	C	46 mm	58 mm	66 mm	82 mm	100 mm	112 mm	125 mm	140 mm

	Feature	Size 77	Size 80	Size 83	Size 87	Size 90	Size 91	Size 92	Size 93
Max. clutch torque at 5,5 bar	T <sub>stat.</sub>	10.000 Nm	13.000 Nm	20.000 Nm	28.500 Nm	38.000 Nm	51.000 Nm	75.000 Nm	105.000 Nm
Max. clutch torque at 6,0 bar	T <sub>stat.</sub>	11.500 Nm	15.000 Nm	22.500 Nm	32.500 Nm	43.000 Nm	57.000 Nm	84.000 Nm	115.000 Nm
Max. brake torque	T <sub>dyn.</sub>	7.300 Nm	9.700 Nm	14.300 Nm	20.800 Nm	27.000 Nm	35.000 Nm	50.000 Nm	70.000 Nm
Speed	n	1.100 min <sup>-1</sup>	1.000 min <sup>-1</sup>	850 min <sup>-1</sup>	750 min <sup>-1</sup>	700 min <sup>-1</sup>	630 min <sup>-1</sup>	560 min <sup>-1</sup>	500 min <sup>-1</sup>
12 pt. suspension	A1	584 mm	640 mm	725 mm	810 mm	890 mm	965 mm	1.080 mm	1.215 mm
2 pt. suspension short	A2	695 mm	770 mm	880 mm	970 mm	1.100 mm	1.180 mm	1.300 mm	1.465 mm
2 pt. suspension long	A3	885 mm	990 mm	1.135 mm	1.235 mm	1.450 mm	1.525 mm	1.645 mm	1.855 mm
Max. bore diameter	B	125 mm	145 mm	160 mm	180 mm	200 mm	220 mm	240 mm	270 mm
Length	C	160 mm	185 mm	205 mm	230 mm	248 mm	260 mm	295 mm	330 mm



### Easy integration

Due to its compact design and various options for the shaft connections such as keyways or clamping devices, the series 420 can easily be integrated into various press drive designs.



### Modular design

The ability to use many different 2-pt. or 12-pt. arrangement combinations, of the clutch and brake suspensions, allows exceptional flexibility in integrating into the press design.



### High engineering competence

Ortlinghaus has been developing clutches and brakes for thousands of different applications for many decades – safe, experienced and reliable.



### Easy connection

Engaged by air, these units can be easily integrated into any press application.

# Clutch-brake unit series 106

Due to market demands that required higher output capacities of presses, the series 106 was developed from Ortlinghaus. The series 106 clutch-brake unit combines the simplicity of the traditional dry-running clutch-brake unit design with hydraulic actuation. This combination simultaneously achieves highest torques on clutch and brake side which cannot be achieved by engagement through pressurized air. In addition, the design of these clutch-brake units enables the use of two friction plates on the brake side, which allow to use a clutch-brake unit of a smaller size than with other clutch-brake designs. All this leads to a higher number of strokes per minute, a reduced braking angle and a lower individual moment of inertia.



## Series 106

Hydraulic dry-running clutch-brake unit

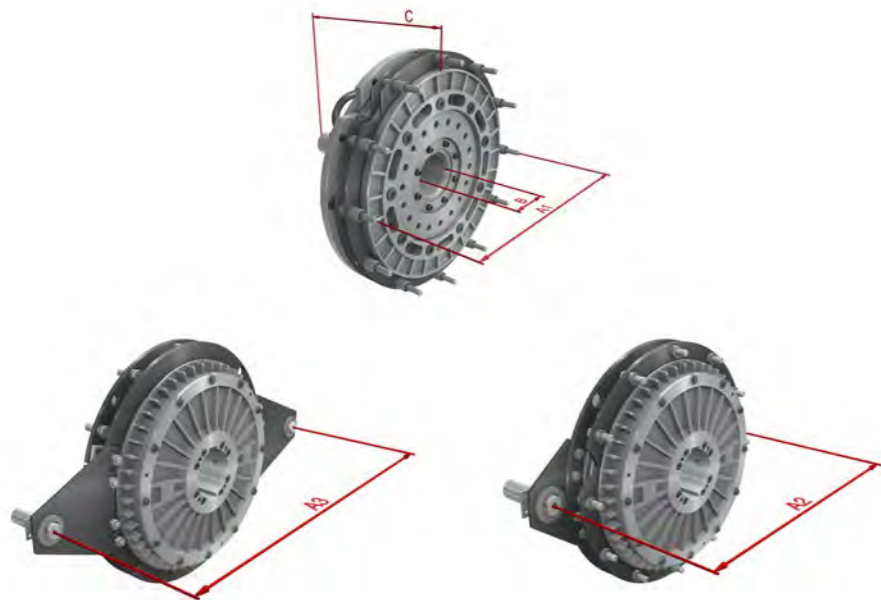

	Feature	Size 79	Size 82
Clutch torque	$T_{stat.}$	24.500 Nm	35.000 Nm
Brake torque	$T_{dyn.}$	28.000 Nm	40.000 Nm
Operating pressure	$p_B$	60 bar	60 bar
Speed	n	1.000 min <sup>-1</sup>	850 min <sup>-1</sup>
12 pt. suspension	A1	640 mm	725 mm
2 pt. suspension short	A2	770 mm	880 mm
2 pt. suspension long	A3	990 mm	1.135 mm
Max. bore diameter	B	115 mm	135 mm
Length	C	286 mm	306 mm



### Easy integration

Due to its compact design and different options for the shaft connections, such as shrink disks or clamping devices, the series 106 can easily be integrated in any press drive designs.



### Fast reaction time

The clutch-brake unit series 106 can be engaged with any common oil up to a viscosity of 150 cSt and achieves fast engagement times due to the hydraulic actuation.



### High torque density

The combination of hydraulically engaged clutch and the use of dry-running friction material ensures highest torques on clutch and brake side, even with small dimensions.

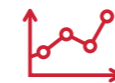

### Short reaction time

The clutch-brake unit can be supplied with a specially designed control unit that ensures short reaction times and high switching speeds.

# Linear Motion Lock series 055

According to DIN EN ISO 16092, the relevant safety standards for press engineering, mechanical presses must have a mechanical restraining device for repair work and tasks between the slide and frame. The Ortlinghaus linear motion lock series 055 is specifically developed for this purpose and is approved by the German employers' liability insurance association. The linear motion lock is used to positively lock the ram via a shaft so that the shaft cannot rotate. This is crucial to ensure that the press ram does not move uncontrollably during maintenance or repair work.



**Series 055**

Linear Motion Lock

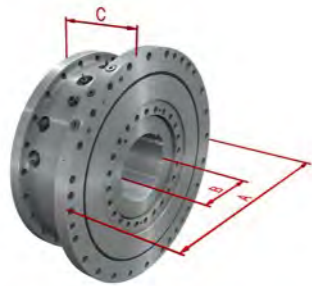

**Full monitoring**

The state of the ram locking mechanism, which is actuated by oil pressure, either locked or unlocked, is detected using inductive travel sensors and transmitted to the machine control unit.



**Easy integration and unique design**

Due to its compact design and the wide range of options for connecting the linear motion lock either outside on the machine frame or inside the machine, the series 055 can be easily assembled and disassembled. The ram can be locked in any position in a very short time.



**High safety level**

The series 055 is a ram locking system for presses according to DIN EN ISO 16092 standard.



**Long service life**

The linear motion lock provides a long lasting device based on the use of form fitting spline connection.

	Feature	Size 86	Size 90	Size 94
Max. holding torque	T <sub>stat.</sub>	22.000 Nm	50.000 Nm	100.000 Nm
Operating pressure	p <sub>B</sub>	30 – 65 bar	30 – 65 bar	30 – 65 bar
Outer diameter	A	538 mm	660 mm	900 mm
Max. bore diameter	B	150 mm	220 mm	260 mm
Length	C	220 mm	262 mm	325 mm

# Clutch series 127 and brake series 128

The hydraulically actuated clutch series 127 is used to accelerate a press ram in single-stroke mode by transferring energy from the flywheel to the ram, designed for very high torques at low speeds. The hydraulically released brake series 128 decelerates the press ram in forging presses during single-stroke mode, offering brake torques of up to 1 million Nm. Because clutch and brake are separate units, both can be individually selected to meet specific requirements. All the benefits of series 123 apply.



**Series 127**

Hydraulic clutch

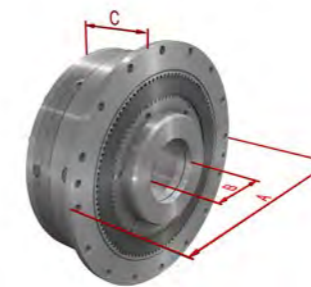

**Series 128**

Hydraulic brake

Series 127	Feature	Size 86	Size 90	Size 94	Size 96	Size 98	Size 99
Min. clutch torque	T <sub>stat.</sub>	22.700 Nm	48.800 Nm	101.900 Nm	189.900 Nm	336.000 Nm	775.700 Nm
Max. clutch torque	T <sub>stat.</sub>	45.500 Nm	96.800 Nm	203.700 Nm	378.700 Nm	672.000 Nm	1.551.000 Nm
Operating pressure	P <sub>B</sub>	80 bar	80 bar	90 bar	90 bar	90 bar	90 bar
Speed	n	850 min <sup>-1</sup>	700 min <sup>-1</sup>	500 min <sup>-1</sup>	415 min <sup>-1</sup>	350 min <sup>-1</sup>	250 min <sup>-1</sup>
Outer diameter	A	550	680	850	1.060	1.230	1.415 mm
Max. bore diameter	B	200 mm	250 mm	320 mm	350 mm	375 mm	500 mm
Length	C	629 mm	657 mm	750 mm	824 mm	1.066 mm	1.153 mm

Series 128	Feature	Size 86	Size 90	Size 94	Size 96	Size 98	Size 99
Min. brake torque	$T_{dyn.}$	9.500 Nm	19.200 Nm	39.700 Nm	77.400 Nm	147.600 Nm	279.000 Nm
Max. brake torque	$T_{dyn.}$	19.100 Nm	38.400 Nm	79.400 Nm	154.700 Nm	295.200 Nm	1.056.000 Nm
Operating pressure	$P_B$	80 bar	80 bar	90 bar	90 bar	90 bar	90 bar
Speed	n	850 min <sup>-1</sup>	700 min <sup>-1</sup>	500 min <sup>-1</sup>	415 min <sup>-1</sup>	350 min <sup>-1</sup>	250 min <sup>-1</sup>
Outer diameter	A	550 mm	680 mm	850 mm	1.060 mm	1.230 mm	1.415 mm
Max. bore diameter	B	200 mm	250 mm	320 mm	350 mm	375 mm	500 mm
Length	C	200 mm	236 mm	320 mm	384 mm	437 mm	547 mm



#### Optimal maintenance conditions

Long maintenance intervals and a high durability lead to less service expenses.



#### High torque density

The multi-plate design with oil cooled friction pairing of steel and high-performance sinter ensures high and consistent torque availability.



#### Easy integration

Due the compact design and the customizable interfaces with keyway or clamping devices for the connection to the shaft, the clutches and brakes of series 127 and 128 can be easily integrated in any press design.



#### High press availability

Both the clutch and the brake are constructed as a closed system and thus protected from external pollution like oily or dusty air, which leads to less downtime and maintenance costs.



#### High engagement speed

The multi-plate design and the low moment of inertia in combination with the Ortlinghaus progressive control guarantee shortest reaction times and high engagement frequencies.



#### System supplier

Both the clutch and the brake can be supplied with an oil inlet, press safety valve or control unit and electronic slipping control (ESC) which allows the monitoring of the oil volume, oil temperatures and the plate conditions.



#### Modular design

The multi-plate design makes it possible to achieve a wide range of different torque sizes and can therefore be perfectly selected to fit the specification of the press.

## Prot.act: Prot.act series 172

The Prot.act brake series 172 is specifically designed for presses driven by servomotors and is used as ram holding and as emergency brake. This brake can be installed in different arrangements, it is either mounted directly next to the servo motor or on the free shaft end. With the superior friction block design, fretting corrosion is completely avoided.



# Series 172

Performance data	Size 82			Size 87			Size 92		
	0172-100-2-disks	0172-200-3-disks	0172-300-4-disks	0172-100-2-disks	0172-200-3-disks	0172-300-4-disks	0172-100-2-disks	0172-200-3-disks	0172-300-4-disks
Execution									
Min. stat. torque <sup>1)+2)</sup>	12.000 Nm	17.100 Nm	21.600 Nm	24.000 Nm	34.000 Nm	43.000 Nm	66.000 Nm	96.000 Nm	125.000 Nm
Max. dyn. torque <sup>1)+2)</sup>	16.700 Nm	23.700 Nm	29.900 Nm	34.000 Nm	48.000 Nm	60.000 Nm	77.000 Nm	112.000 Nm	145.000 Nm
Min. required pressure	95 bar	95 bar	95 bar	95 bar	95 bar	95 bar	95 bar	95 bar	95 bar
Max. release pressure	120 bar	120 bar	120 bar	120 bar	120 bar	120 bar	120 bar	120 bar	120 bar

Dimensions	Size 82			Size 87			Size 92		
A - Outer Ø	453 mm	453 mm	453 mm	548 mm	548 mm	548 mm	762 mm	762 mm	762 mm
C - Length	249 mm	282 mm	315 mm	271 mm	310 mm	349 mm	314 mm	364 mm	414 mm
B - Shaft connection <sup>3)</sup>	Shrink disk for shafts -Ø: 95 H7 – 110 H7			Shrink disk for shafts -Ø: 120 H7 – 135 H7 or tothing			Shrink disk for shafts -Ø: 120 H7 – 180 H7 or tothing		
Weight	~ 209 kg	~ 229 kg	~ 254 kg	~ 310 kg	~ 350 kg	~ 391 kg	~ 628 kg	~ 793 kg	~ 863 kg

1) minimum values in delivery condition  
 2) brake torque in worn conditions is provided in the specific calculation of the press  
 3) shrink disk design for shafts Ø in 5mm increments available

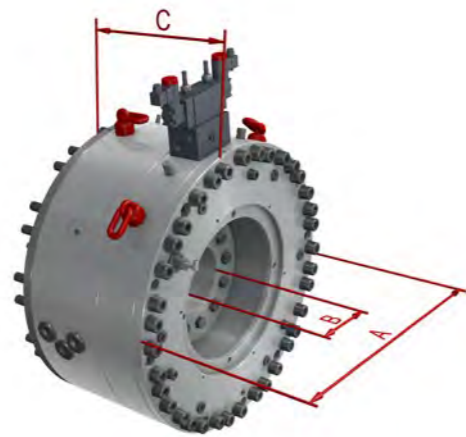

## Prot.act

The solution for your specific press design.

The new Prot.act series 172 can be installed in different arrangements. The brake is mounted directly on either side of the motor or on a free shaft end.

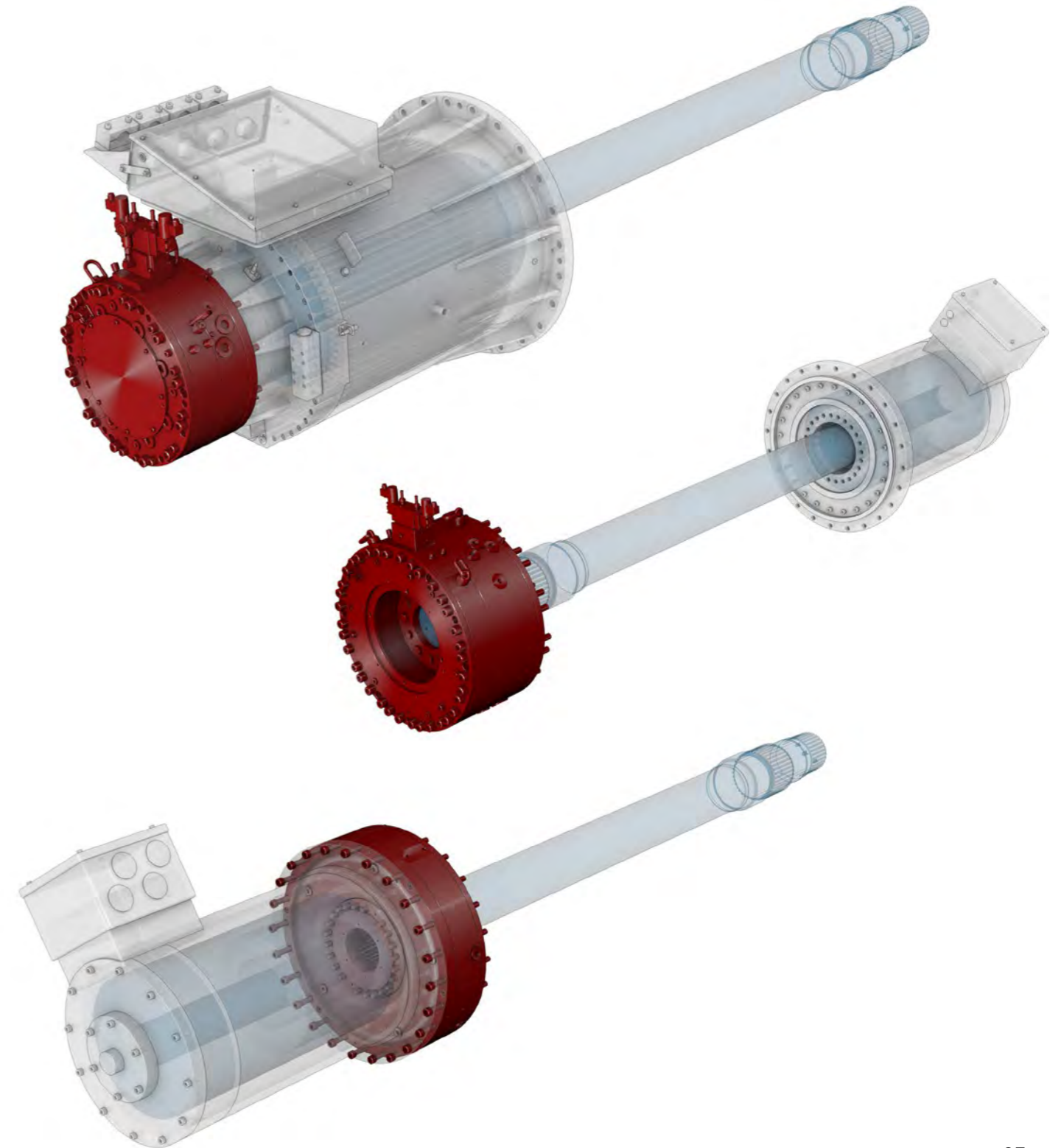

## Industry 4.0 ready

Monitored safety

The Prot.act can be equipped with a sensor package to provide real time information on the brake condition to the press control.

### Temperature sensor

Due to the possibility of measuring the temperature of the friction surface, a breakdown can be avoided.

### Piston way sensor

Wear measurement allows a predictive maintenance.

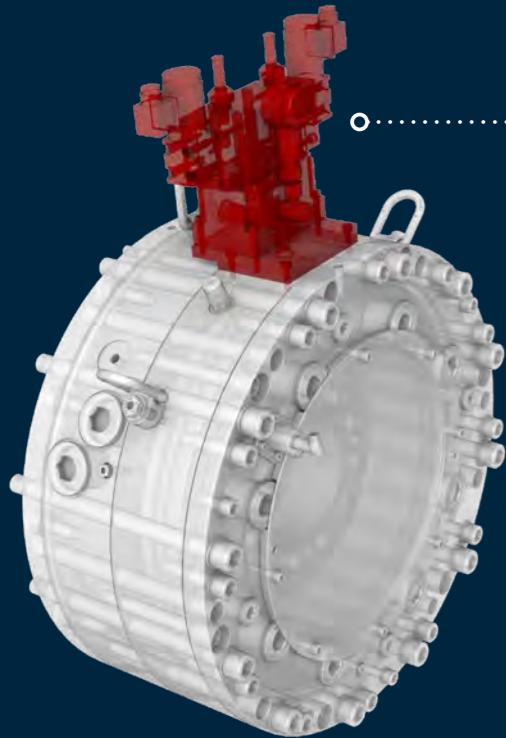
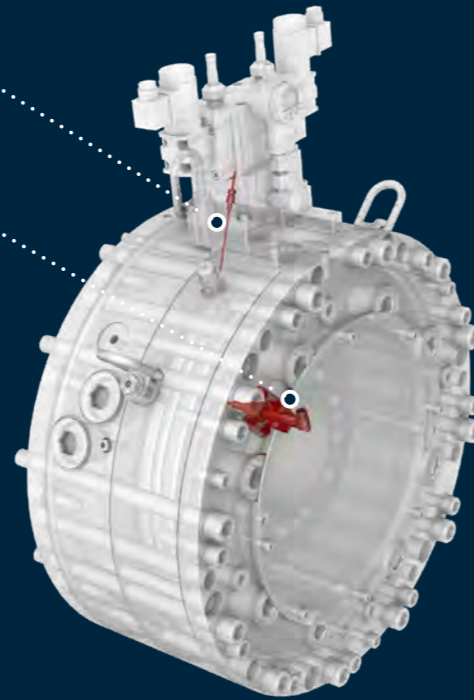

**Press safety valve**  
Permanent pressure monitoring ensures functionality.



### Durability and safety

The Prot.act provides a long service life due to innovative design, durability and functional reliability.



### Worldwide service

Our global network, which consists of more than 25 branch offices, sales partners and service points, ensures quick assistance in every situation.



### High press availability

The brake can be supplied with an optional cover and labyrinth sealing in order to be protected against external pollution like oily or dusty air, which leads to less maintenance costs.



### Verified quality

End-of-line testing of each and every brake provides first class quality to the market. Certified torque values and reaction times are documented with the product.



### Easy integration

With its mounting and centering aid a fast integration into the press is guaranteed.



### Ready for industry 4.0

A sensor kit with temperature and wear sensors enables predictive maintenance planning and reduces the downtime of the press.

# Prot.act series 472

The Prot.act brake series 472 is specifically designed for presses driven by servomotors and is used as ram holding and as emergency brake. This brake can be installed in different arrangements, it is either mounted directly next to the servo motor or on the free shaft end. With the superior friction block design, fretting corrosion is completely avoided.



## Series 472

Pneumatic dry-running brake for servo presses

Performance data	Size 82
Execution	0472-200-3-disks
Min. stat. torque <sup>1) + 2)</sup>	8.100 Nm
Max. dyn. torque <sup>1) + 2)</sup>	12.300 Nm
Min. required pressure	4,5 bar
Max. release pressure	6,0 bar

1) minimum values in delivery condition

2) brake torque in worn conditions is provided in the specific calculation of the press

Dimensions	Size 82
A - Outer Ø	510 mm
C - Length	197,4 mm
B - Shaft connection	Clamping device 140 × 190 mm
Weight	~ 145 kg



### Easy connection

Engaged by air, these units can be easily integrated into any press application.



### Durability and safety

The Prot.act series 472 provides a long service life due to innovative design, durability and functional reliability.



### Optimal maintenance conditions

Long maintenance intervals and a high durability lead to less service expenses.



### Easy integration

With its mounting and centering aid a fast integration into the press is guaranteed.



### High press availability

The brake can be supplied with an optional cover and labyrinth sealing in order to be protected against external pollution like oily or dusty air, which leads to less maintenance costs.



### Verified quality

End-of-line testing of each and every brake provides first class quality to the market. Certified torque values and reaction times are documented with the product.



### Design-to-cost

The design-to-cost approach enables us to offer a product with a much higher price performance compared with conventional brakes. This aspect covers the entire process from the assembly to the operation of the product for years.

# Oil inlet

Ortlinghaus has been manufacturing single and multi-channel rotary inlets for several decades, which are frequently supplied as accessories for oil actuated and oil cooled clutches. These tried and tested machine components for supplying pressure and cooling oil to rotating shafts are standard products and can not only be used in conjunction with clutches. The oil inlets are available in axial and radial versions. In addition, Ortlinghaus also develops and manufactures rotary inlets according to customer's requirements, which are not listed in the catalogue of our standard products. For example, it is possible to manufacture rotary inlets with more than three channels which can conduct different media.

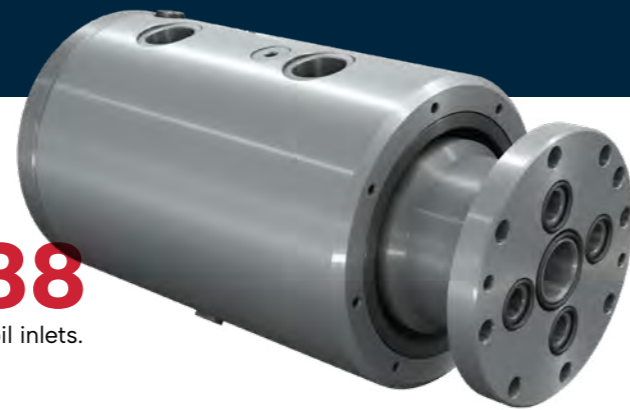

## Series 088

Our oil inlets are also available as radial oil inlets.



### Easy integration

Ortlinghaus can supply various mounting options for oil inlets for different setups, which enables easy integration.

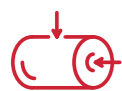

### One or two channel executions available

Ortlinghaus supplies one and two channel oil inlets. Additional channels on request.

Series 088	Feature	Size 22	Size 27	Size 35
Pressure max. <sup>1)</sup>	P <sub>B</sub>	100 bar	100 bar	100 bar
Speed max. <sup>2)</sup>	n	1.500 min <sup>-1</sup>	1.500 min <sup>-1</sup>	1.500 min <sup>-1</sup>
Outer diameter <sup>3)</sup>	A	120 mm	160 mm	180 mm
Length	L	165 mm	247 mm	288 mm
Number of channels/connections <sup>4) 5)</sup>	i × M	2 × G1/2	2 × G3/4	2 × G1

1) higher pressures on request  
 2) higher speeds on request  
 3) without oil catching ring, oil catching ring on request  
 4) multi-channel executions for higher oil volumes on request  
 5) at operating viscosity 68 cSt and pressure loss ≤ 2 bar at 50°C

# Control unit series 086

Ortlinghaus supports customers in selecting the right control system to achieve the optimal engagement process for the clutches and brakes and supplies different control components such as press safety valves or progressive controls, that are used for the control of hydraulically actuated clutches and brakes as well as of clutch-brake units.

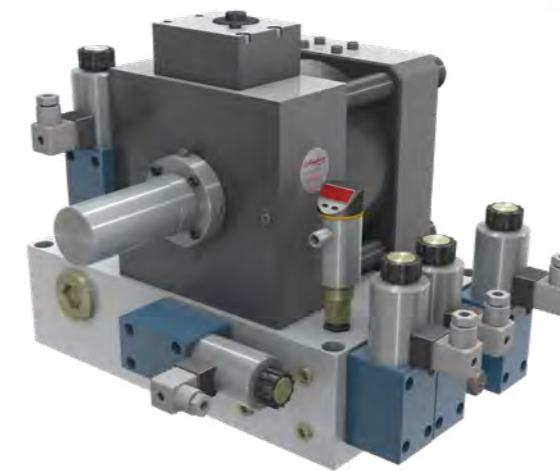

Economic control solution with press safety valves

Progressive control units inclusive press safety valves



### Hard braking and hard engagement

Direct engaging of the brake with full braking torque in case of emergencies.



### Soft engagement and operating comfort

With the optionally available version with a particular valve arrangement, a soft engagement of the clutch can be realized through a very flexible and sensitive pressure control.



### Soft braking

Engaging the brake with adjustable brake counterpressure to allow a soft stop of the machine.



### Monitoring of operating conditions

Easy integration with the machine's PLC allows for monitoring of the operating conditions.



# Digital protection for your forming machines

The new and innovative DC650 diagnosis and control platform was developed by Ortlinghaus to meet the demands of the market for digitalization.

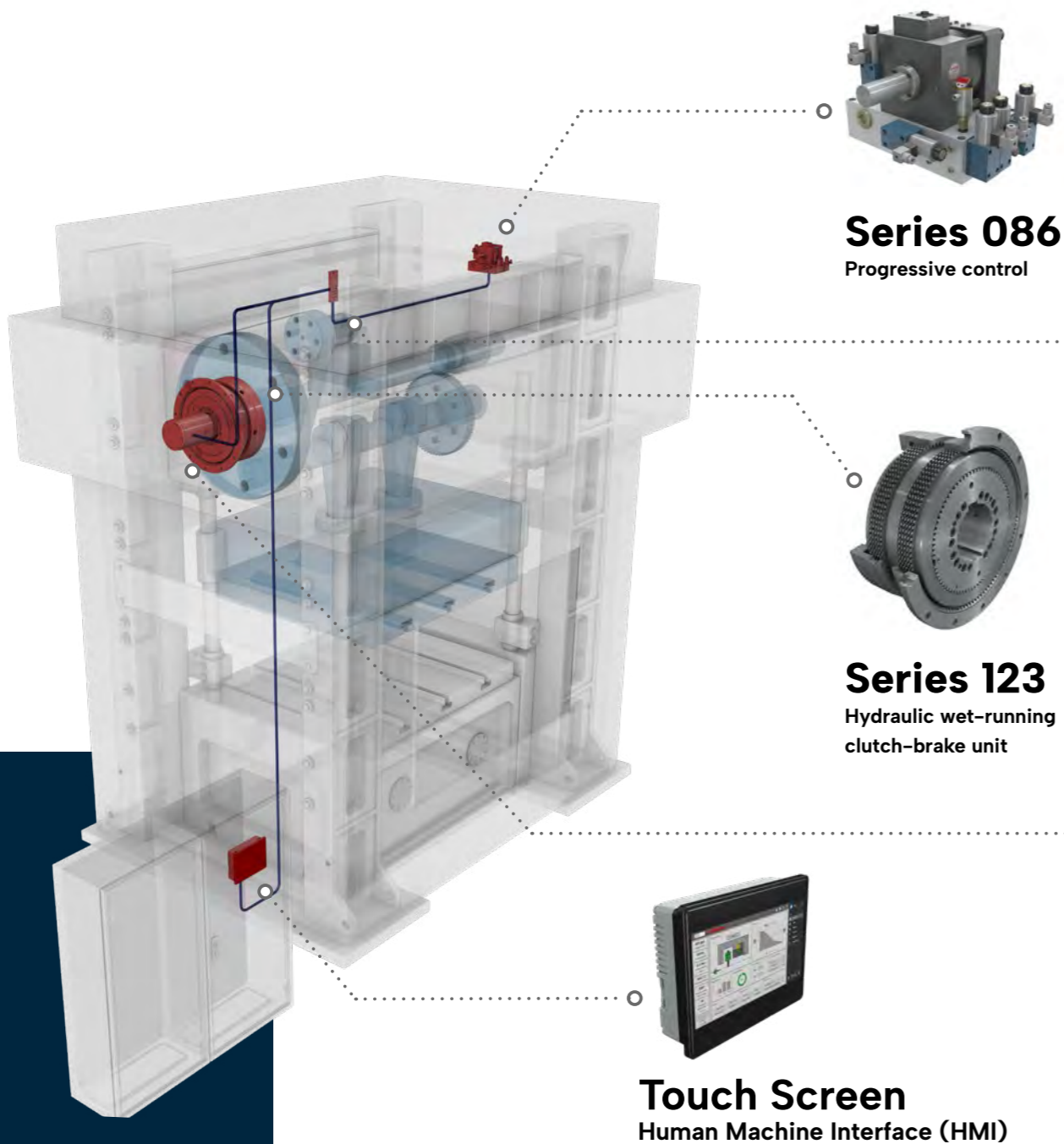

## Diagnosis and control platform

# DC650

The DC650 is a scalable, flexible and highly compatible solution for both simple and complex diagnostic purposes. Designed for clutches, brakes and clutch-brake units in metal forming technology – also for our Prot.act series safety brakes.

Robust hardware and modern software enable application-specific monitoring of our technology.

With the integration of the DC650, condition values are measured seamlessly, critical conditions are detected and a machine breakdown may be prevented.

Our technical support and/or necessary spare parts can then be ordered in time before a machine breakdown occurs, thus improving the long-term availability of the machine.

As a machine builder or operator you can benefit from the advantages of the DC650 in next to no time through simple integration into the existing machinery.

## Integrated system solution

The DC650 combines Ortlinghaus hardware with a modern, self-developed and secure software.



# Hardware

### Customizable fieldbus connectivity

- Profinet, Modbus/TCP
- CAN bus based protocols



### Scalability

- Multiple units can be combined to increase I/O capacity

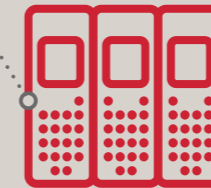

### Communication with cloud services

- Connection via LAN
- Communication via MQTT



### Integration of different sensor types

- Pressure
- Speed
- Temperature
- etc.

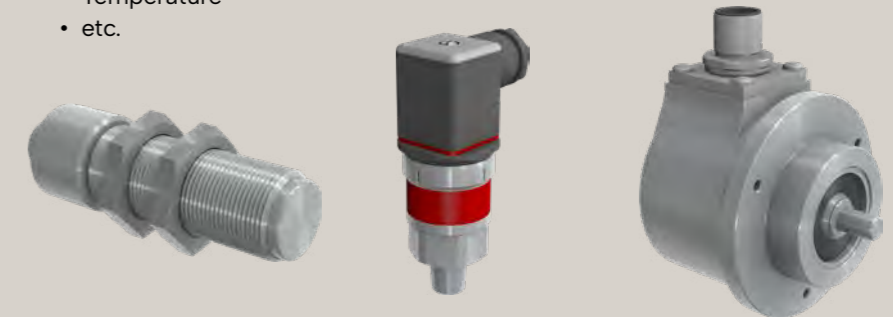

### Integrated web server

- Access per web browser
- No extra software required



# Software

### Parameter editor

- Clearly structured management of all parameters

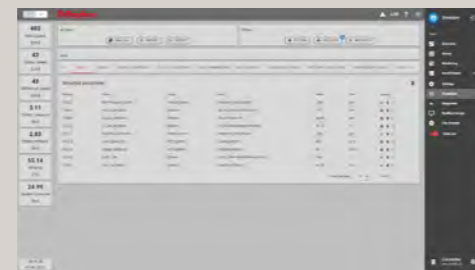

### Notifications and error list

- List of current and previous information
- Timecode for each entry



### Application view

- Everything at a glance in the process overview
- Practical value bar for permanent control



### Scope function

- Useful scope function and convenient export function for data analysis

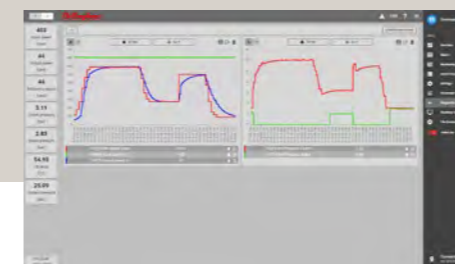

### IT security

- Ortlinghaus software based on IEC 62443
- Wi-Fi can be deactivated
- No need for local network integration



### General functions

- Intuitive software update via browser
- Easy log file download

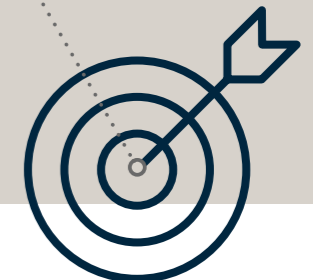

# Benefits

Arrange a product presentation with us and experience the advantages and possibilities of the DC650 for yourself.



**Long-term data acquisition of operating states through:**

- Integrated memory function
- Extended memory function through optional cloud connection



**Lower maintenance costs through:**

- Early detection of wear to minimise the need for spare parts
- Planned maintenance intervals with optional remote maintenance



**Increased machine availability through:**

- Continuous condition monitoring of process parameters such as speeds, pressures and flow rates
- Determination of the thermal load of Ortlinghaus clutches, brakes and clutch-brake combinations
- Detection of critical conditions
- Warning in case of wear, (sensor) defects and excessive pressure loss



**Lower preventive maintenance costs through:**

- Remote access to status data (optional cloud-based remote access to status data)
- Condition diagnosis with the aid of memory data
- Condition diagnosis during press operation, which does not require machine downtime



**Increased safety through:**

- System shutdown in case of emergency



**Quick and easy commissioning of the Ortlinghaus technology through:**

- Complete integration of the DC650 into the machine structure

# Technical data



- Clutch pressure
- Output speed
- Input speed
- Additional pressure sensors
- Cooling oil flow rate

# DC650

Technical data	DC650
Diagnosos-LEDs	1 × Status, 1 × Warning, 1 × Error, 2 × Application, 1 × Safety warning, 1 × Safety error
Power supply	19 – 36 V DC, galvanically isolated, redundant
<b>Interfaces</b>	
Network	1 × Ethernet 10/100 Mbit/s, M12 D-coded
Bus protocols	Profinet/Modbus/TCP, CAN
Bus interfaces	2 × Ethernet, M12 D-coded
<b>Other</b>	
Protection class	IP65
Web visualization	Yes
Dimensions	340 mm × 120 mm × 35 mm

# In good hands from the beginning

Get in touch to one of our experts.

### Enquiry

- via contact form on our website [www.ortlinghaus.com](http://www.ortlinghaus.com)
- directly via email to [metal@ortlinghaus.com](mailto:metal@ortlinghaus.com)
- contact through one of our worldwide sales representatives [www.ortlinghaus.com](http://www.ortlinghaus.com) | Contacts & Media | Contacts

### Technical consultancy

- many thousands of products for different applications
- selection of technically and economically best fitting products

### Order

- quick response times
- friendly support
- flexible order handling

### Production

- more than 100 years of production know-how
- high quality

### Delivery

- safe and reliable shipping methods according to customer requirements
- worldwide delivery
- known consigner

### After Sales

- worldwide after-sales-services
- high availability
- commissioning
- [service@ortlinghaus.com](mailto:service@ortlinghaus.com)

- Sales & Service hub with spare parts
- Sales & Service hub

## Ortlinghaus worldwide

Founded in: 1898

Subsidiaries: Ortlinghaus (U.K.) Ltd./England  
 Ortlinghaus France Transmissions sarl/France  
 Ortlinghaus AG/Switzerland  
 Ortlinghaus Drive Technology (Shanghai) Co., Ltd/China  
 Ortlinghaus Drive Technology India Pvt.Ltd./India  
 Ortlinghaus America Latina/Brasil

Manufacturing: Wermelskirchen/Germany  
 Gams/Switzerland  
 Jinan/China

Sales: Worldwide via agencies

Original spare parts    Product overhaul at Ortlinghaus    Service & repair worldwide    Condition check    High availability of After-Sales-Service (24/7)



Ortlinghaus-Werke GmbH  
Kenkhauser Str. 125 42929  
Wermelskirchen  
Germany

Phone: +49 (0) 21 96 85-0  
info@ortlinghaus.com  
[www.ortlinghaus.com](http://www.ortlinghaus.com)

Orttech LLC  
32425 Aurora Rd  
Solon, OH 44139 2821  
USA

Phone: +1 440-498-7458  
sales@orttech.com  
[www.orttech.com](http://www.orttech.com)

